

ENGINEERING DATA
STROMBERG-CARLSON NO. 450 RADIO RECEIVERS

STROMBERG-CARLSON TELEPHONE MANUFACTURING COMPANY
ROCHESTER, NEW YORK

IDENTIFICATION TABLE

Model	Input Power Frequency	Chassis	Cabinet	Speaker
450-M	50-60 Cycles	30162	30164	27504
450-MB	25-60 Cycles	30163	30164	27504

SPECIFICATIONS

Type of Circuit.....	Superheterodyne with Electric Tuning
Tuning Ranges.....	A—.53 to 1.7 Mc.; B—2.3 to 7.5 Mc.; C—7.5 to 23 Mc.
Number of Tubes.....	Eleven
Type of Tubes.....	6K7, R. F. Amplifier 6A8, Modulator 6J5, Oscillator 6K7, I. F. Amplifier 6H6, Demodulator 6SQ7, Audio Amplifier 6SQ7, Audio Inverter 6F6G, Output (2) 5Z3, Rectifier 6AF6G, Tuning Indicator
Voltage Rating.....	105 to 125 Volts
Power Frequency Rating.....	Standard 50-60 Cycles, also available 25-60 Cycles
Input Power Rating.....	120 Watts
Intermediate Frequency.....	455 Kilocycles
Speaker Voice Coil Impedance at 400 Cycles.....	Approximately 1.5 Ohms
Speaker Field Coil Resistance.....	505 Ohms

FEATURES

General

This is an eleven tube, three gang, three band, high fidelity receiver, designed for operation with the Stromberg-Carlson senior Acoustical Labyrinth and Carpinchoe Speaker.

The chassis is of the fortified type with bails provided for ease in handling and servicing. Automatic tuning is accomplished by means of a motor drive controlled by a commutator and brush assembly, and the dial is of the slide rule type, edge-lighted for clear visibility without glare. Separate treble and bass controls are provided to make possible accurate adjustment of the tone, and the chassis is designed to be easily converted for use with remote control or phonograph.

This chassis is designed to provide the maximum in sensitivity and selectivity and excellent tone quality for the discriminating customer. It should also be relatively free from the "birdies, tweets and whistles" and interference of the type found in some smaller sets.

Special Circuits

A tuning indicator having two apertures, one for strong signals and one for weak signals, is used with this chassis. One aperture will close with a signal of approximately 100,000 microvolts, and the other will not close even with a two volt signal.

Iron core coils are used in the IF and RF circuits to provide greater stability and, in addition, a thermal drift compensator is included in the circuit.

The high frequency end of each band is spread out by means of special capacitor plates, to provide greater ease in tuning and automatic low level bass compensation is provided.

The audio system employs a special inverter push-pull circuit designed to provide excellent fidelity and the chassis is thoroughly shielded throughout with an electro-statically shielded power transformer.

Automatic Tuning

Twelve push buttons are provided. From right to left their operation is as follows:

- 1 Manual Control
- 2 Remote Control
- 3-10 Pre-set Stations (8)
- 11 Phonograph
- 12 Off Switch

Pushing any button (except the Off button) turns the set on and tuning is accomplished by means of an electric motor driving the regular variable capacitor to a pre-set point.

Setup is very easily accomplished by means of a switch which causes the pilot light to go out when the brush is properly located.

Remote Control

Remote selection of stations may be accomplished by simply plugging the remote control box into the socket provided on the back of the chassis and a motor to control the volume can be readily attached to the volume control shaft.

The identifying number of the package containing the remote control box, motor and all necessary parts is 30387 for 50-60 cycles and 30391 for 25 cycles.

Phonograph Operation

A socket is provided on the back of the chassis into which a record player may be plugged, and a switch is provided on the front of the chassis for switching from "Radio" to "Phonograph".

Television

Switching to "Phonograph" also makes the audio amplifier and loud speaker available for use with television receivers designed for this type of sound reproduction.

ACCESSORIES

Antenna

For best results use a Stromberg-Carlson Antenna. These Antennas are supplied in kits containing all the necessary parts for mounting and installation and are designed especially for use with all Stromberg-Carlson receivers.

Playing Records

To obtain the best quality of phonograph reproduction a Stromberg-Carlson record player is recommended. They are designed for use with this receiver, and all that is necessary is to connect the record player to the single prong socket provided in the chassis and proceed to operate. The volume and tone may be controlled with the controls at the receiver, or (if such is provided) the volume control on the record player may be used.

A low impedance pick-up may also be used, but a matching transformer must be placed between the phonograph pick-up and the chassis.

Remote Control

Stromberg-Carlson has prepared a "Remote Tuning Control Unit" which may be easily installed on these receivers. This Unit enables the user to select any one of the eight favorite stations which have been previously set up on the electric tuning system at a distance from the receiver up to the length of the attached cable. A motor and two push buttons are also included for controlling the volume. These units complete with accessories and installation instructions are available in package assemblies P. 30387 for use with 50-60 cycle receivers and P. 30391 for use with 25 cycle receivers.

Headset Attachment

Headphones can be very simply attached to this receiver. Ask for Pc. No. 28303 Headset Package Assembly, which comes complete with headphones and installation instructions.

Care of Cabinet

The finish of Stromberg-Carlson Cabinets should be protected by using Stromberg-Carlson Cabinet Polish regularly. It is available in pint cans, designated as Pc. No. 28601.

Nicks and scratches of most kinds can be repaired quickly and easily by proper use of the Pc. No. 26962 Touch-Up Kit. Complete instructions are provided with each kit.

Tools

Stromberg-Carlson can supply all the tools required for working on these sets. For example:

SD-29 Phillips Head Screwdriver

No. 24608 Aligning Tool

Also pliers, cutters, screwdrivers, etc.

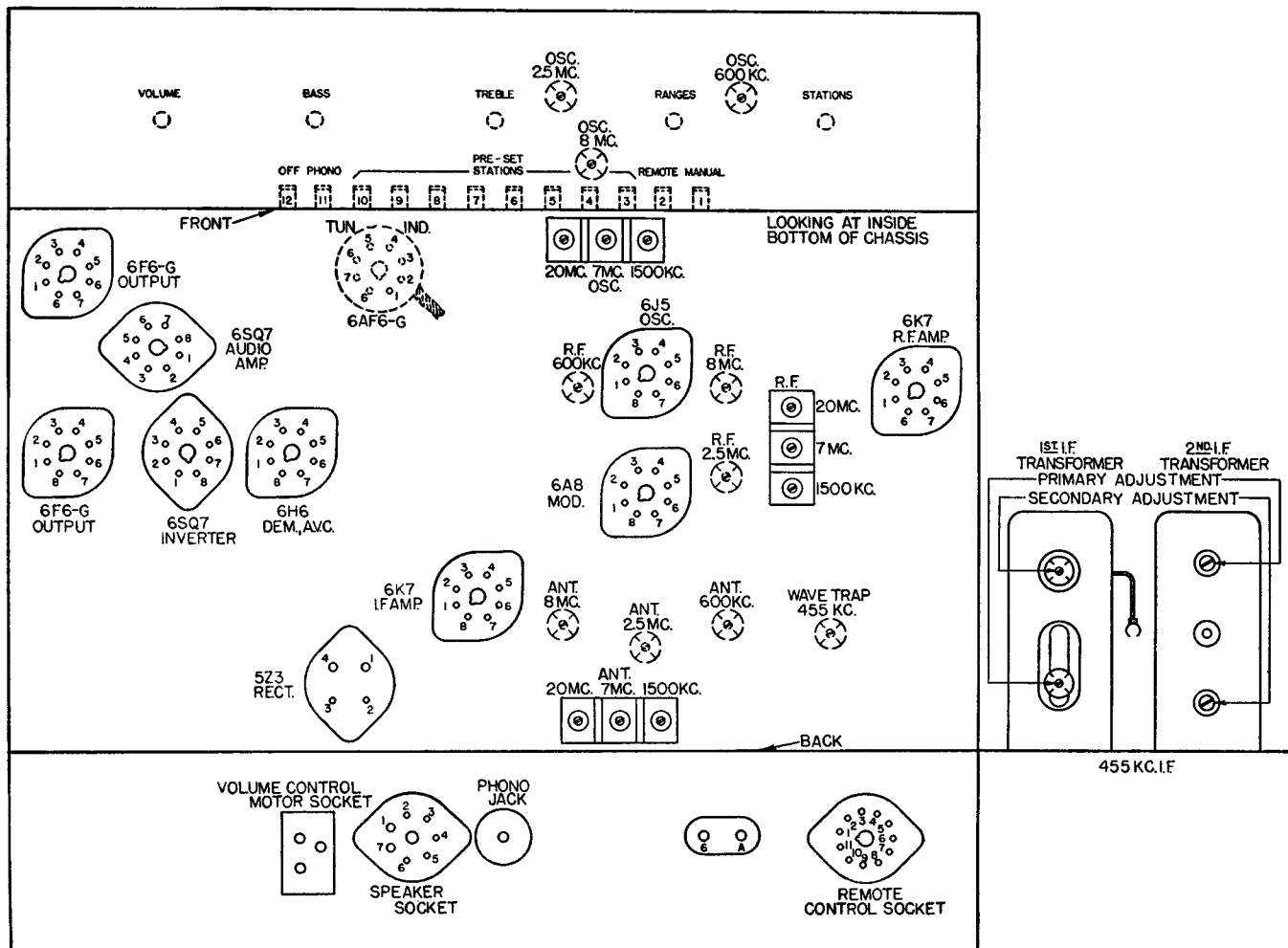

Location Chart

ALIGNING INFORMATION

NEVER ALIGN UNLESS ABSOLUTELY NECESSARY.

Use a good modulated signal generator (test oscillator) with variable output voltage and a sensitive output meter across the voice coil of the speaker.

Always align using the smallest possible input from the signal generator (except when wave trap adjustment is made). A strong signal makes adjustments inaccurate.

Always have receiver volume control full on.

Never align with tone control in "Bass" position.

See location chart above for location of all the aligning adjustment screws.

Aligning Procedure (follow this order exactly)

I. Dial pointer adjustment.

With the plates of the gang tuning capacitor fully engaged, set the dial pointer directly on the vertical line located at the extreme low frequency end of the short-wave band.

II. Intermediate frequency adjustments.

1. Push in the "Manual" push button.

2. Set the range switch to Standard Broadcast position.

3. Tune set to extreme low frequency end of the dial.

4. Connect the ground terminal of the signal generator to the ground terminal of the chassis.

5. Introduce a modulated signal of 455 Kilocycles to the grid cap of the 6A8G Tube, using a 0.1 microfarad capacitor in series with the output lead of the signal generator. (Do not remove the grid clip from this tube.)

6. Adjust the I. F. Aligners for maximum output in the following order:
 - A. Secondary of second I. F. transformer.
 - B. Primary of second I. F. transformer.
 - C. Secondary of first I. F. transformer.
 - D. Primary of first I. F. transformer.
- III. Radio frequency adjustments.
- Short Wave Range (C Band)**
1. Replace the 0.1 microfarad capacitor in series with the output lead of the signal generator with a 400 ohm carbon type resistor, and connect it to the antenna terminal of the chassis.
 2. Set the range switch to the short-wave range position (C Band).
 3. Set the signal generator frequency and the receiver tuning dial to 8 megacycles.
 4. Adjust the 8 megacycle oscillator R. F. and antenna iron cores for maximum signal.
 5. Set the signal generator frequency and the receiver tuning dial to 20 megacycles.
 6. Adjust the 20 megacycle oscillator R. F. and antenna aligning capacitors for maximum signal.
 7. Repeat operations three and four.
 8. Repeat operations five and six.
- Medium Wave Range (B Band)**
1. Leave the receiver connected in the same manner as when adjusting the Short-Wave Range (C Band).
 2. Set the range switch to the medium wave range position (B Band).
 3. Set the signal generator frequency and the receiver tuning dial to 2.5 megacycles.
 4. Adjust the 2.5 megacycle oscillator, R.F. and antenna iron cores for maximum signal.
 5. Set the signal generator frequency and the receiver tuning dial to 7.0 megacycles.
 6. Adjust the 7 megacycle oscillator, R. F. and antenna aligning capacitors for maximum signal.
 7. Repeat operation three and four.
 8. Repeat operation five and six.
- Standard Broadcast Range (A Band)**
1. Replace the 400 ohm carbon type resistor in series with the output lead from the signal generator with a 200 micro-microfarad capacitor.
 2. Set the range switch to the Standard Broadcast Range (A Band).
 3. Set the signal generator frequency and the receiver tuning dial to 600 Kc.
 4. Adjust the 600 Kc. oscillator R. F. and antenna iron cores for maximum signal.
 5. Set the signal generator frequency and the receiver tuning dial to 1500 Kc.
 6. Adjust the 1500 Kc. oscillator R. F. and antenna aligning capacitors for maximum signal.
 7. Repeat operation three and four.
 8. Repeat operation five and six.
- IV. **Wave Trap Adjustment.**
- (Leave the receiver connected in the same manner as when adjusting the Standard Broadcast Range ("A" Band)).
1. Tune set to 1000 Kc.
 2. Set the signal generator frequency to 455 Kc. and introduce a fairly strong modulated signal to the receiver.
 3. Adjust the wave trap aligner for minimum signal.

ADJUSTING DIAL LAMP

The dial on this receiver is edge lighted, and for proper illumination it is **very important** that the dial light be adjusted so that the filament is exactly opposite the edge of the glass.

To make this adjustment simply slide the pilot light socket back and forth on its mounting bracket until maximum illumination is obtained.

NORMAL VOLTAGE READINGS

Take all readings with chassis operating and tuned manually to 1000 Kc.—no signal.

Use a line voltage of 120 volts, or make allowance for the variation.

Use a good high resistance voltmeter having a resistance of at least 1000 ohms per volt.

Take all D. C. readings on the 500 volt scale except when an asterisk appears.

Read from indicated terminals to chassis base.

See location chart on Page 3 for position of terminals.

A. C. voltages are indicated by italics.

To measure voltages of 6AF6G tube remove the metal cover on the tuning indicator socket and read from indicated terminals.

Tube	Circuit	Cap	Terminals of Sockets								Heater Voltages Between Heater Terminals	
			1	2	3	4	5	6	7	8	Socket Terminal Numbers	Volts A. C.
6K7	R. F. Amp.	0	0	0	+250	+106	+3*	—	6.5	+3*	2-7	6.5
6A8	Modulator		0	0	+250	+96	-20*	+96	6.5	+2*	2-7	6.5
6J5	Oscillator	0	0	0	+156	—	-20*	—	6.5	0	2-7	6.5
6K7	I. F. Amp.	0	0	0	+250	+100	+3*	—	6.5	+3*	2-7	6.5
6H6	Demodulator	—	0	0	0	0	0	—	6.5	0	2-7	6.5
6F5	Audio Inv.	0	0	0	—	+136	—	—	6.5	0	2-7	6.5
6F5	Audio Amp.	0	0	0	—	+159	—	—	6.5	0	2-7	6.5
6F6	Output	—	0	0	+316	+322	0	—	6.5	+21*	2-7	6.5
6F6	Output	—	0	0	+316	+322	0	—	6.5	+21*	2-7	6.5
6AF6G	Tun. Ind.	—	0	0	+100	+106	+225	—	6.5	+90	2-7	6.5
5Z3	Rectifier	—	+410	400	400	+410	—	—	—	—	1-4	5
Speaker Socket		—	+400	0	+410	+410	+410	—	310	—		

*Read on lowest possible scale of voltmeter.

CONTINUITY TEST

CAUTION: Remove all tubes and disconnect the receiver from the power supply before making continuity test.

Use a good meter capable of measuring accurately up to several megohms.

The resistances given are often approximate, owing to electrolytic capacitors in the circuit.

When this is the case, be sure to reverse the test leads and read the highest resistance.

Read from the indicated terminals to chassis base unless otherwise specified.

See location chart on Page 3 for position and numbering of terminals.

TERMINALS OF SOCKETS										
Tube	Circuit	Cap	1	2	3	4	5	6	7	8
6K7	R. F. Amp.	2.7M	S	S	20,000 Ω	80,000 Ω	390 Ω	20,000 Ω	S	390 Ω
6A8	Modulator	2.7M	S	S	20,000 Ω	80,000 Ω	47,000 Ω	80,000 Ω	S	390 Ω
6J5	Osc.	—	S	S	42,000 Ω	32,000 Ω	47,000 Ω	32,000 Ω	S	S
6K7	I. F. Amp.	100,000 Ω	S	S	20,000 Ω	*	390 Ω	**	S	390 Ω
6H6	Demodulator	—	S	S	1M	190 Ω	470,000 Ω	1M	S	S
6SQ7	Audio Amp.	—	S	10M	S	S	S	280,000 Ω	S	S
6SQ7	Audio Inv.	—	S	10M	S	S	S	320,000 Ω	S	S
6F6G	Output	—	S	S	20,000 Ω	20,000 Ω	390,000 Ω	100,000 Ω	S	190 Ω
6F6G	Output	—	S	S	20,000 Ω	20,000 Ω	390,000 Ω	100,000 Ω	S	190 Ω
5Z3	Rectifier	—	22,000 Ω	500 Ω	500 Ω	22,000 Ω	—	—	—	—
6AF6G	Tun. Ind.	—	O	S	250,000 Ω	80,000 Ω	17,000 Ω	O	S	7,000 Ω
Speaker Socket		—	.5M or Greater	S	S	O	.5M or Greater	O	17,000 Ω	—

Symbols used are as follows: Ω —ohms; M—megohms; S—short; O—open.

- * Push "Phono" button in—"open".
Push "Manual" button in—100,000 ohms.
- ** Push "Phono" button in—"open".
Push "Manual" button in—32,000 ohms.

Other tests not shown on chart

Test from phono jack on back of chassis base;

- Push "Phono" button in—1 megohm.
- Push "Manual" button in—"open".

Antenna terminal to chassis base—70 ohms.

Ground terminal to chassis base—"short".

Test between terminals of A. C. plug;

- Push "Off" button in—"open".
- Push "Manual" button in—3 ohms.
- Terminals of A. C. plug to chassis base—"open".

R. F. coil tests measured directly across R. F. coil terminals with range switch set in standard position (A Band).

- L1—1 ohm, L2—3 ohms, L3—2 ohm, L4—.2 ohm, L5—.2 ohm, L6—"short", L7—70 ohms,
- L8—"short", L9—1 ohm, L10—.2 ohm, L11—.3 ohm, L12—.5 ohm, L13—.1 ohm, L14—.5 ohm, L15—4 ohms, L16—.2 ohm, L17—.3 ohm, L18—.2 ohm, L19—.2 ohm.

INSTRUCTIONS FOR SETTING UP PUSH BUTTONS

IMPORTANT: The stations selected should be the local or favorite stations which give good reception at all times.

Set up stations in the daytime to avoid unnecessary interference.

Allow the set to run for about twenty minutes before setting up stations.

Always use the tuning indicator unit when setting up stations in order to determine when the station is exactly in tune.

1. Put the call letters of the selected stations in place above the push buttons. The stations should be arranged according to frequency with the highest frequency at the right and the lowest frequency at the left, just as on the dial. (The call letters will be found inside the envelope stapled inside or underneath the cabinet).
2. Set the "Treble" control in normal position.
3. Turn the set-up switch (located on the base just back of the brush and commutator assembly) to the set-up position. (The slot in the screw should point toward "set-up").
4. Push the button of the highest frequency station to be set up (button No. 3) and then tune in that station manually. Be sure the station is exactly "in tune" by tuning carefully and watching the cathode ray indicator.
5. Slide the brush to which the blue wire is connected until it is over the slot in the commutator. Then adjust it very carefully until the pilot light goes out. This indicates exact adjustment.
6. Repeat operations 4 and 5 for each station. Work from right to left or from the higher to the lower frequencies in accordance with the table below:

Push Button No.	Purpose	Color of wire on brush
1	Manual	—
2	Remote	—
3	Highest frequency station	Blue
4	Next lower frequency station	Orange
5	Next lower frequency station	Green
6	Next lower frequency station	Brown
7	Next lower frequency station	Slate
8	Next lower frequency station	Red
9	Next lower frequency station	Black
10	Lowest frequency station	Blue White
11	Phonograph	
12	Off	

} See diagram on last page.

7. Turn the set-up switch back to the "Operate" position.
8. Check the operation of all the push buttons to be sure that each has been accurately set up. If it is necessary to readjust any of the buttons, follow the procedure given above.

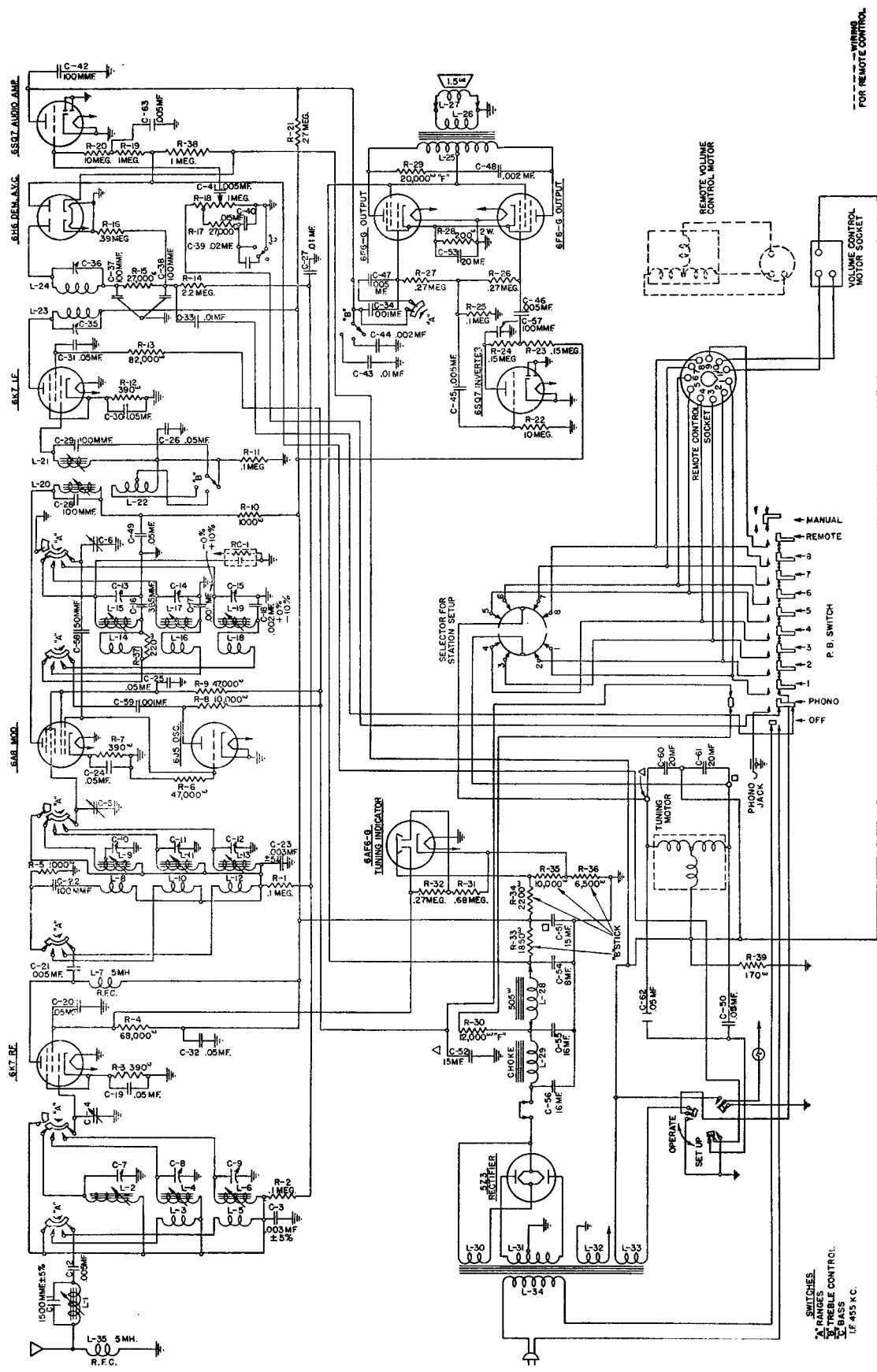

Schematic Circuit

FOR REMOTE CONTROL

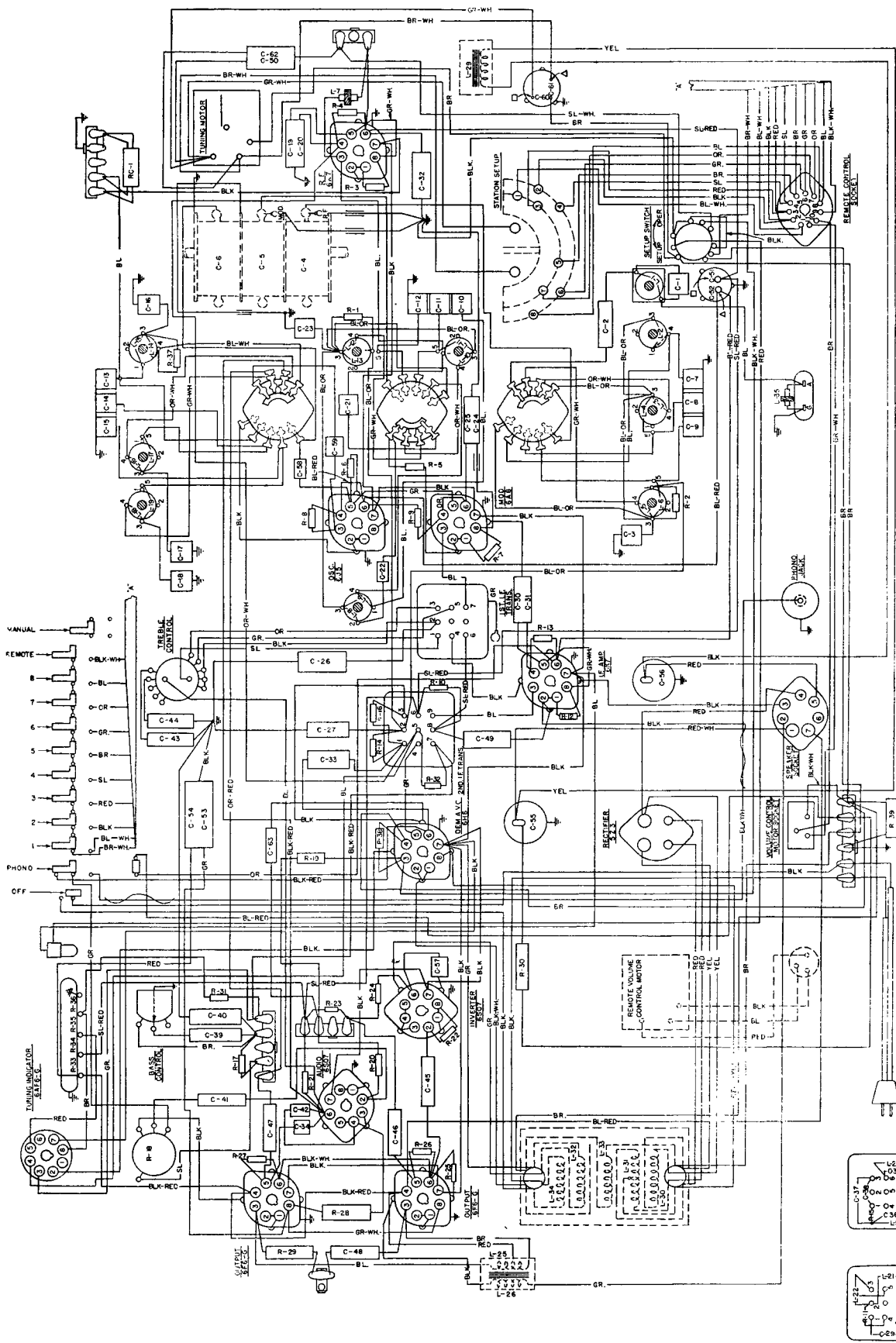

Wiring Diagram

REPLACEMENT PARTS

Use genuine Stromberg-Carlson parts. It will be to your advantage. They are made for use in Stromberg-Carlson receivers. The specifications are correct and the same high quality material and workmanship is used as in the whole radio receiver. Don't ruin a good receiver with an inferior part.

Capacitors

Piece Number	Circuit Designation	Part
24559	C-22, 42, 57	100 mmf.
24994	C-32, 49, 26	.05 mf.
25149	C-33, 43, 27	.01 mf.
25150	C-39	.02 mf.
25487	C-34, 59	.001 mf.
26778	C-21	.005 mf.
27108	C-18, 20, 24, 25, 26, 27, 30, 31	2—.05 mfs.
27305	C-58	50 mmf.
27646	C-44, 48	.02 mf.
28594	C-40	.015 mf.
30116	C-23	.003 mf.
30251	C-17	.001 mf.
30252	C-18	.002 mf.
30322	C-2, 41, 45, 46, 47, 63	.005 mf.
27143	C-10, 11, 12	Aligning Capacitor
30253	C7, 8, 9, 13, 14, 15	Aligning Capacitor
27336	C-55	1—16 mf. 500 V (Electrolytic)
27622	C-56	1—16 mf. 500 V (Electrolytic)
30231	C-51, 52	1—15 mf. 350 V (Electrolytic) 1—15 mf. 300 V (Electrolytic)
30232	C-53, 54	1—8 mf. 350 V (Electrolytic) 1—20 mf. 35 V (Electrolytic)
30282	C-4, 5, 6	Tuning Capacitor (3 gang)
30539	C-60, 61	2—20 mfs. Electrolytic 120 V A.C.

Coils, Transformers and Speaker

30143	L-5, 6	Antenna Coil C Band
30144	L-16, 17	Oscillator Coil B Band
30145	L-18, 19	Oscillator Coil C Band
30146	L-12, 13	R. F. Coil C Band
30147	L-3, 4, 10, 11	Antenna and R. F. Coil B Band
30148	L-8, 9	R. F. Coil A Band
30149	L-2, 3	Antenna Coil A Band
30150	L-14, 15, C-16	Oscillator Coil A Band
30233	L-29	Choke Assembly
30332	L-7, 35	R. F. Choke
30238	L-1, C-1	Wave Trap
30229	L-30 to L-34 inc.	Power Transformer 50/60 Cycles
30230	L-30 to L-34 inc.	Power Transformer 25/60 Cycles
30242	L-20, 21, 22, C-28, 29	1st I. F. Transformer
30245	L-23, 24, C-35, 36	2nd I. F. Transformer
30247	L-25, 26	Output Transformer
27504		Speaker
26250		Cone for Speaker

Controls and Knobs

27313		Fidelity and Tone Control
30236		Range Switch
30249	R-18	Volume Control
30279		Switch Assembly P. B. Key
30250		Bass Switch
30327		Set-up Switch
27800		Small Plain Knob
27801		Knob with Arrow
27628		Felt Washer for Knobs

REPLACEMENT PARTS—Continued

Piece Number	Circuit Designation	Part
Resistors		
26325	R-37	220 Ohms—Type E
26328	R-3, 7, 12	390 Ohms—Type E
26333	R-5, 10	1000 Ohms—Type E
26345	R-8	10,000 Ohms—Type E
26350	R-17	27,000 Ohms—Type E
26353	R-6, 9	47,000 Ohms—Type E
26355	R-4	68,000 Ohms—Type E
26356	R-13	82,000 Ohms—Type E
26357	R-1, 2, 251 Megohm—Type E
26359	R-23, 2415 Megohm—Type E
26362	R-21, 26, 27, 3227 Megohm—Type E
26364	R-1639 Megohm—Type E
26367	R-3168 Megohm—Type E
26369	R-19, 38	1 Megohm—Type E
26373	R-14	2.2 Megohm—Type E
26381	R-20, 22	10 Megohm—Type E
26775	R-29	20,000 Ohms—Type F
26776	R-30	12,000 Ohms—Type F
28956	R-28	200 Ohms IRC
30235	R-33, 34, 35, 36	Voltage Divider
30605	R-39	170 Ohm—Type F
Miscellaneous Parts		
26122	Antenna and Ground Terminal Strip
26287	Pilot Lamp
26678	3-Prong Socket
29786	Pilot Lamp Socket Assembly
30151	8-Prong Socket
30152	7-Prong Socket
30153	4-Prong Socket
30223	11-Prong Socket
28652	Power Supply Cord
29162	Spring
29628	Spring for Drive Cord
30065	Dial
30169	Station Call Letters
30172	Dial Escutcheon
30176	Electric Tuning Escutcheon
30341	Screw for Mtg. Dial Escutcheon
30345	Screw for Mtg. Electric Tuning Escutcheon
30224	Phono. Plug
30225	Phono. Guard
30226	Phono. Jack
30256	Shaft for Motor Drive (Vol. Control)
30262	Motor for Dial Drive
30265	Pulley
30934	Set Screws for Pulley Assembly
30276	Dial Pointer
30286	Commutator Assembly
30295	Brush Holder
30385	Brush (Inside Slot)
30297	Brush (Outside Slot)
30261	Tuning Indicator Cable
30299	Cable (Plug to Push Buttons)
30292	RC-1	Compensator Unit
30275	Bronze Drive Cord Assembly
Tools and Accessories		
SD-29	Phillips No. 1 Screwdriver
24608	Aligning Tool
28601	Cabinet Polish (Pt. Can)
26962	Furniture Touch-Up Kit
28303	Headphone Package Assembly

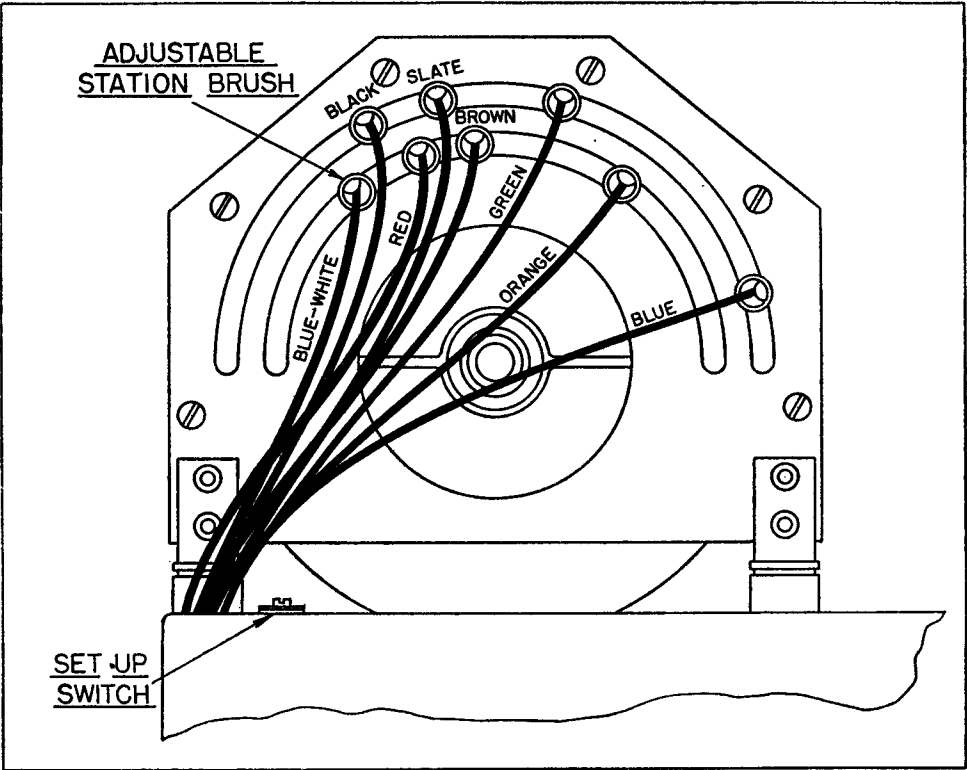

Showing Adjustable Station Brushes and Set Up Switch.